

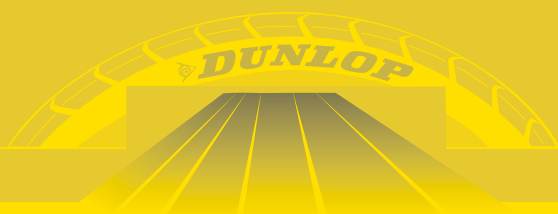

DRIVERS
KNOW.

SP 482

New mixed service drive tyre





SP482 – NEW MIXED SERVICE DRIVE TYRE

The SP482 features latest technology compounds and materials in view of providing best mileage combined with excellent damage resistance and traction properties to mixed service fleet operators.

The deep radial shoulder grooves combined with the centreline rib allow for excellent traction characteristics and handling. The specific groove geometry is designed to minimize stone holding and to provide good self-cleaning properties.

The SP482 features the unique TPL (Top Polyamide Layer) technology, a corrosion resistant polyamide barrier, which protects the high strength steel belts from penetration damage. In addition, the polyamide material prevents moisture from entering the carcass. Combined to the other protective features of the SP482, the TPL technology significantly improves damage resistance and durability as well as retreadability, providing additional value to the customer.

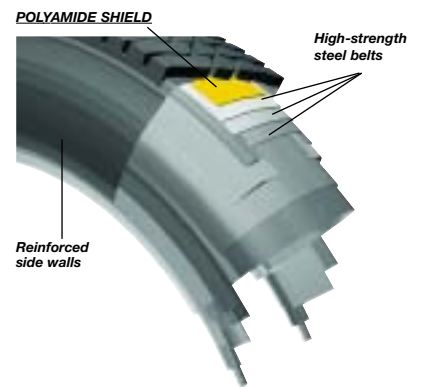

FEATURES	BENEFITS
Latest tread compound technology	Excellent mileage performance in toughest services
Tread pattern, centerline rib, deep and open radial shoulder grooves	Outstanding traction performance on and off road, good self-cleaning
Robust tread design and carcass construction	Excellent chip/chunk and damage resistance
TPL technology (Top Polyamide Layer)	Excellent durability and retreadability
Groove shapes optimized to minimize stone holding	Optimum damage resistance



Size line up and technical details:

SIZE	Load/Speed Index	Max. Axle Load single (kgs)	Max. Axle Load dual (kgs)	Max. Inflation (bar)	Max. Outside Diameter (mm)	Max. Section Width (mm)	Static Loaded Radius (mm)	Rolling Circumf. (mm)	Min. Dual Spacing (mm)	Rec. Rim Width
13R22.5	156/150G 154/150K	8000	13400	8.75	1146	326	521	3430	351	9.0"
315/80R22.5 *	156/150K	8000	13400	8.5	1096	318	500	3280	351	9.0"
295/80R22.5 *	152/148K	7100	12600	8.5	1062	310	487	3180	335	9.0"
12.00R20 *	154/150K	7500	12600	8.5	1146	319	515	3420	360	8.5"

(*in preparation)

Regrooving information:

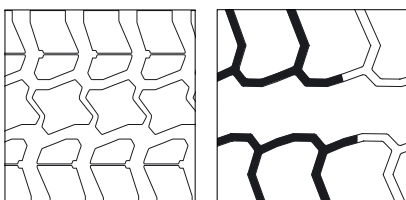

Regrooving depth: 3mm
 Regrooving width: 6-8mm
 Regrooving must be done by professionals. Non-professional regrooving damages tyres and causes premature tyre removal.

